

No. 12 / AUT 12 **5th prolongation**
CERTIFICATE OF JUMPING HILL
CERTIFICAT DE CONFORMITE
SCHANZENPROFILBESTÄTIGUNG

Date of issue 13.07.2024
 Établi le
 Ausgestellt am

Valid till 31.04.2029
 Valable jusq' au
 Gültig bis

Place: Villach

Name: HS 98

HS = 98 m h/n = 0,57 Vo = 23,50 m/s

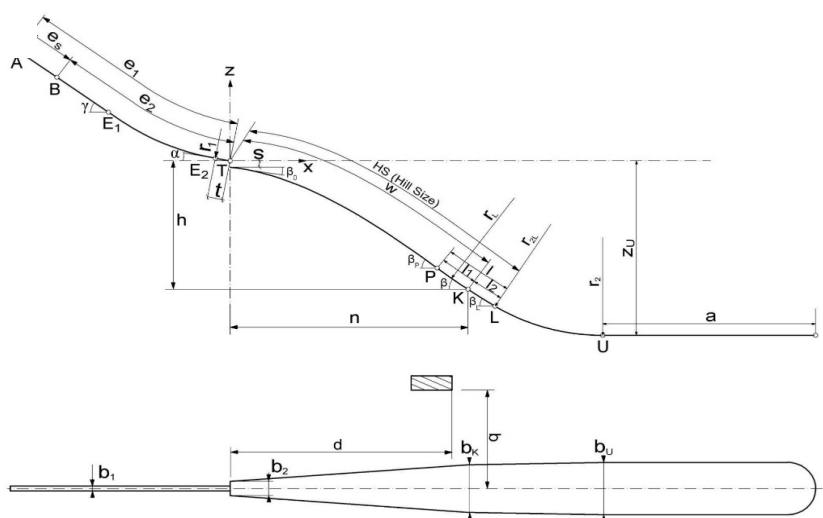

$e_1 = 79,50 \text{ m}$	$l = 16,00 \text{ m}$	$P = 82,00 \text{ m}$
$e_2 = 59,50 \text{ m}$	$l_1 = 8,00 \text{ m}$	$K = 90,00 \text{ m}$
$e_s = 20,00 \text{ m}$ 26 gates à 62,5cm; à 35/55c	$l_2 = 8,00 \text{ m}$	$L = 98,00 \text{ m}$
$t = 5,90 \text{ m}$	$a = 94,00 \text{ m}$	$b_1 = 2,80 \text{ m}$
$\gamma = 35,20^\circ$	$\beta_p = 35,40^\circ$	$b_2 = 7,60 \text{ m}$
$\alpha = 11,60^\circ$	$\beta = 36,00^\circ$	$b_K = 18,70 \text{ m}$
$r_1 = 84,00 \text{ m}$	$\beta_L = 32,50^\circ$	$b_A = 20,70 \text{ m}$
$h = 44,65 \text{ m}$	$r_L = / \text{ m}$	$d = 62,00 \text{ m}$
$n = 78,36 \text{ m}$	$r_{2L} = / \text{ m}$	$q = 35,50 \text{ m}$
$s = 2,77 \text{ m}$	$r_2 = 109,00 \text{ m}$	$Z_U = / \text{ m}$

Remarks / Bemerkungen

- inspection by Pietro Vanzo (13th July 2024)
- the remarks in the inspection-report must be observed and fulfilled for the validity of the certification.
- for fulfilling the (FIS/ICR) standards of the jumpinghills, the owner is responsible during training and competition.

JUMPING HILL APPROVED BY THE FIS
 TREPLIN HOMOLOGUE PAR LA FIS
 DURCH DIE FIS GENEHMIGTE SPRUNGSCHANZE

SUB-COMMITTEE FOR JUMPING HILLS

CHAIRMAN:

Hans-Martin Renn